

NOTES:

1. UNIT Z-8957 SHOWN WITH PROPOSED REWORKED TOP BEAM ON CUSTOMER PIERS
2. UNIT CAPACITY WITH PROPOSED REWORKED TOP BEAM INSTALLED: 440,000 LBS (200MT)
3. UNIT CAPACITY ASSUMES STRUCTURE IS IN GOOD AS SOLD CONDITION AND REQUIRES SERVICE INSPECTION
4. TOP BEAM REQUIRES RE-WORK FOR THE ADDITION OF FLANGES
5. PROPOSED TOP BEAM REWORK BASED ON CURRENT ICW OF 34'-0" (CUSTOMER TO CONFIRM)
6. SHOWN WITH (8) 10" X 56' NYLON 4-PLY SLING SETS
7. FOR RECOMMENDED PIER INFORMATION CONSULT OUR LAUNCHING PIERS DATA SHEET
8. CURRENT STEERING OK

THIS DOCUMENT MAY CONTAIN CONFIDENTIAL, PRIVILEGED OR PROPRIETARY INFORMATION AND IS INTENDED SOLELY FOR THE USE OF THE INDIVIDUAL, GROUP OR ENTITY TO WHOM IT IS ADDRESSED AND MUST NOT BE SHARED WITH THIRD PARTIES WITHOUT THE WRITTEN CONSENT OF MARINE TRAVELIFT INC. THE CONTENT OF THIS DOCUMENT IS FOR INFORMATIONAL PURPOSES ONLY AND DOES NOT REPRESENT A CONTRACT OR ENGAGEMENT OF ANY SORT. IF YOU ARE NOT THE INTENDED RECIPIENT YOU ARE NOTIFIED THAT DISCLOSING, COPYING, DISTRIBUTING OR TAKING ANY ACTION IN RELIANCE ON THE CONTENTS OF THIS INFORMATION IS STRICTLY PROHIBITED.

THIS DOCUMENT AND THE INFORMATION CONTAINED HEREIN IS THE PROPERTY OF MARINE TRAVELIFT INC. AND SHALL NOT BE DISCLOSED OR USED BY A RECIPIENT EXCEPT AS SPECIFICALLY AUTHORIZED BY MARINE TRAVELIFT INC.

PROJECT NUMBER
109-0204

MODEL
BOATHOIST - 200BFM

TYPE
GENERAL ARRANGEMENT

ORDER NUMBER
Z-8957

LATEST REVISION DESCRIPTION
INITIAL RELEASE

ALL DIMENSIONS ARE NOMINAL		NAME	DATE
DRAWN	TWK	1/28/2022	
REVISED	TWK	1/28/2022	
APPROVED			

PRELIMINARY

SIZE **B**

DE

SC

MARINE TRAVELIFT SHUTTLEIFT

49 EAST YEW STREET STURGEON BAY, WI 54235

CUSTOMER SIGNATURE _____ PRINTED NAME _____ DATE _____

DEALER SIGNATURE _____ PRINTED NAME _____ DATE _____

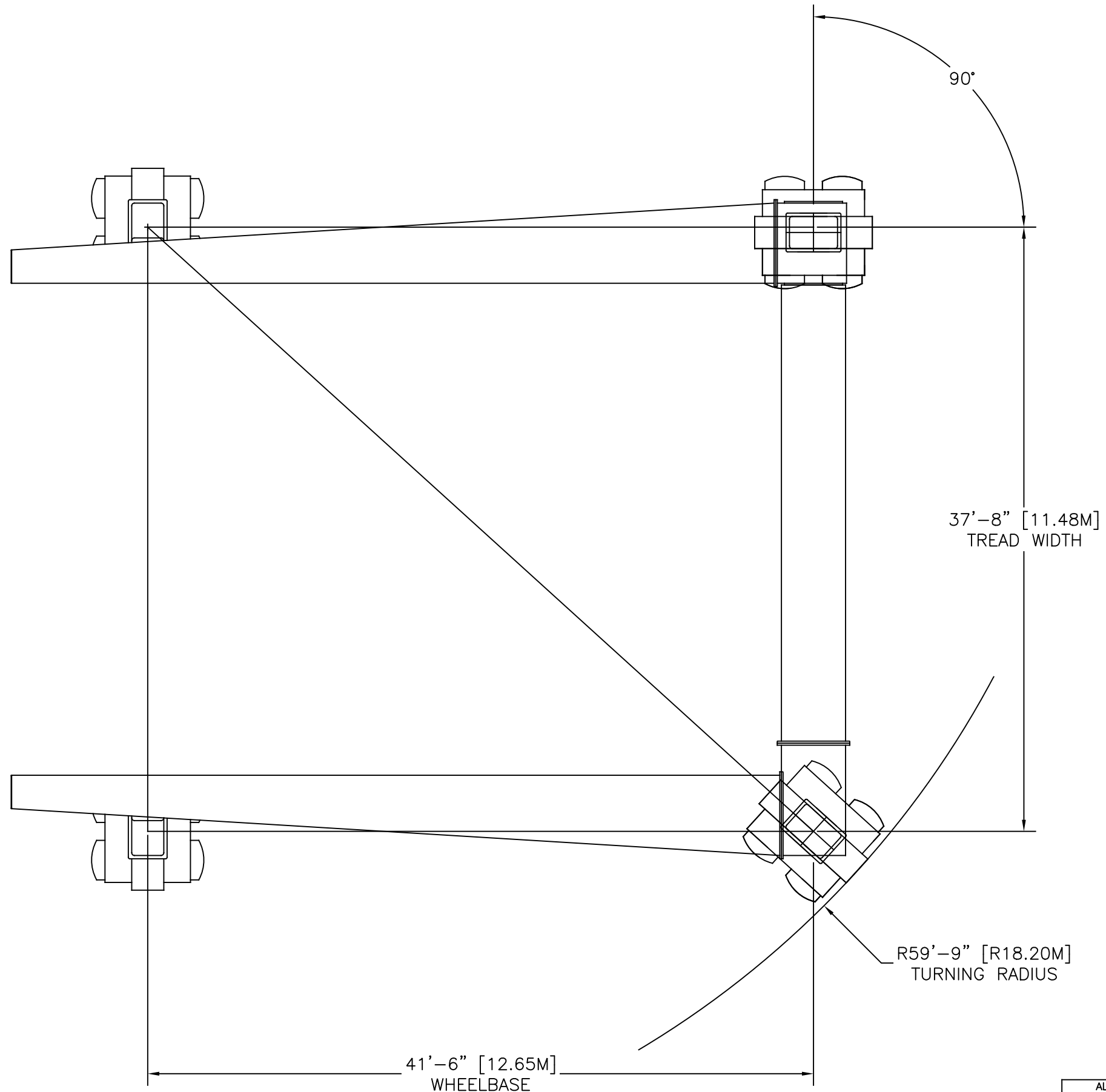

ALL DIMENSIONS
ARE NOMINAL

THIS DOCUMENT AND THE
INFORMATION CONTAINED
HEREIN IS THE PROPERTY OF
MARINE TRAVELIFT INC. AND
SHALL NOT BE DISCLOSED OR
USED BY A RECIPIENT EXCEPT AS
SPECIFICALLY AUTHORIZED BY
MARINE TRAVELIFT INC.

SIZE
B
D
S

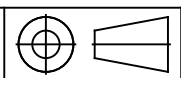

PRELIMINARY

**MARINE TRAVELIFT
SHUTTLELIFT**
49 EAST YEW STREET STURGEON BAY, WI 54235